

Surrogate Key, Version 1.0

URL

<http://www.wiley.com/compbooks/poole/patterns/SurrogateKey.pdf>

Contributor

John Poole (jpoole@alum.poly.edu)

Structural Classification

Micro pattern

Usage Category

Structural

Intent

Provides a means for defining unique keys whose values are anonymous; i.e., the key values are unique identifiers, but otherwise carry no specific semantic meaning.

Also Known As

- Serial key
- Anonymous key

Motivation

Values of surrogate keys contain no semantic content; they are often referred to as being *opaque* to the applications using them, and are used specifically as a means of joining structures together. They have no meaning otherwise. How their values are generated is up to the underlying implementation or system, but has no meaning to end-users of the joined structures. Often, surrogate values consist of unique, but otherwise anonymous, integer values.

Applicability

Surrogate keys are often used in data warehouses to construct the dimensional tables implementing the data analysis store. Whenever a dimensional lookup table needs to be modified, new surrogate key values are generated according to some established algorithm that guarantees unique values. New member records can easily be added to dimensional tables, and existing records may be updated or versioned in a straightforward manner because of the anonymous identities of the surrogate key values. Surrogate keys facilitate *graceful upgrades* to the dimensional structure of the data warehouse.

Projection

The Surrogate Key pattern is based on a sub-graph of the CWM metamodel consisting of the meta classes

- org.omg.cwm.objectmodel.core.Class
- org.omg.cwm.objectmodel.core.Attribute
- org.omg.cwm.objectmodel.core.DataType
- org.omg.cwm.objectmodel.core.Stereotype
- org.omg.cwm.foundation.keysindexes.UniqueKey

and the associations

- org.omg.cwm.objectmodel.core.ElementOwnership
- org.omg.cwm.objectmodel.core.ClassifierFeature
- org.omg.cwm.objectmodel.core.StructuralFeatureType
- org.omg.cwm.objectmodel.core.StereotypedElement
- org.omg.cwm.objectmodel.core.StereotypeTaggedValues
- org.omg.cwm.foundation.keysindexes.UniqueFeature

This sub-graph is illustrated in the diagram below:

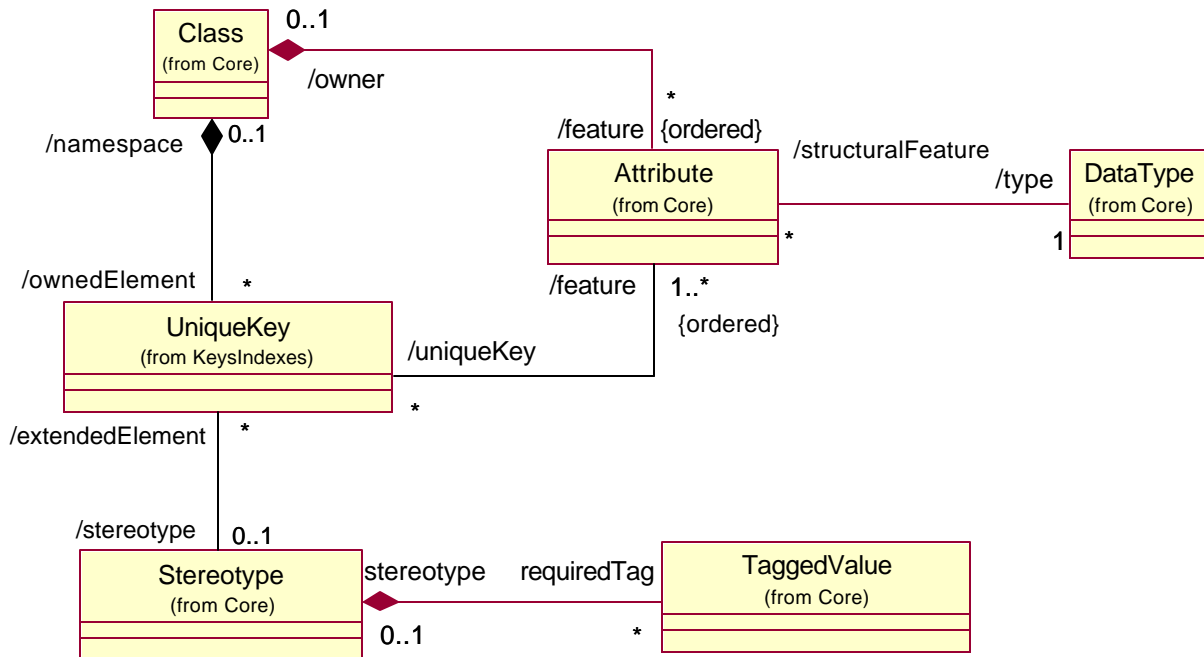

Figure 1: Surrogate Key Projection

Restriction(s)

Restrictions on instances of the projection are as follows:

- The Stereotype instance attached to the instance of UniqueKey must be named "surrogateKey"
- Optionally, a single TaggedValue instance may be attached to the Stereotype, identifying the encoding algorithm used to generate the key values. The tag attribute must be set to "encoding". The value attribute is supplied by the end-user and not specified by the pattern.

This restriction is formally expressed by the following OCL constraints:

```
context Stereotype inv: self.ModelElement::name = "surrogateKey"
context TaggedValue inv: self.tag = "encoding"
```

Usage

This pattern is typically used as a constructional or structural pattern in the realization of higher-level domain patterns that can benefit from the use of surrogate keys in structuring unique key relationships between objects.

Parameters

M2 Parameter	M1 Value	Comments
Stereotype.ModelElement::name	"SurrogateKey"	Value is fixed.
TaggedValue.tag	"encoding"	Value is fixed.
TaggedValue.value	User-defined	Value is a user-supplied name of the surrogate key encoding or generation algorithm.

Commentary

None.

Consequences

TBD

Known Uses

TBD

Related Patterns

Since Surrogate Key makes use of a Stereotype and (optional) TaggedValue, this pattern is often combined with the Local Stereotype pattern, as a means of cleanly establishing where the Stereotype is stored in an interchange stream.

Sample Solution

The instance diagram below illustrates an occurrence of the Surrogate Key pattern. In this example, a single surrogate key is defined as the primary key of a simple relational table. The corresponding XMI fragment shows how the table definition would appear in an XMI interchange stream.

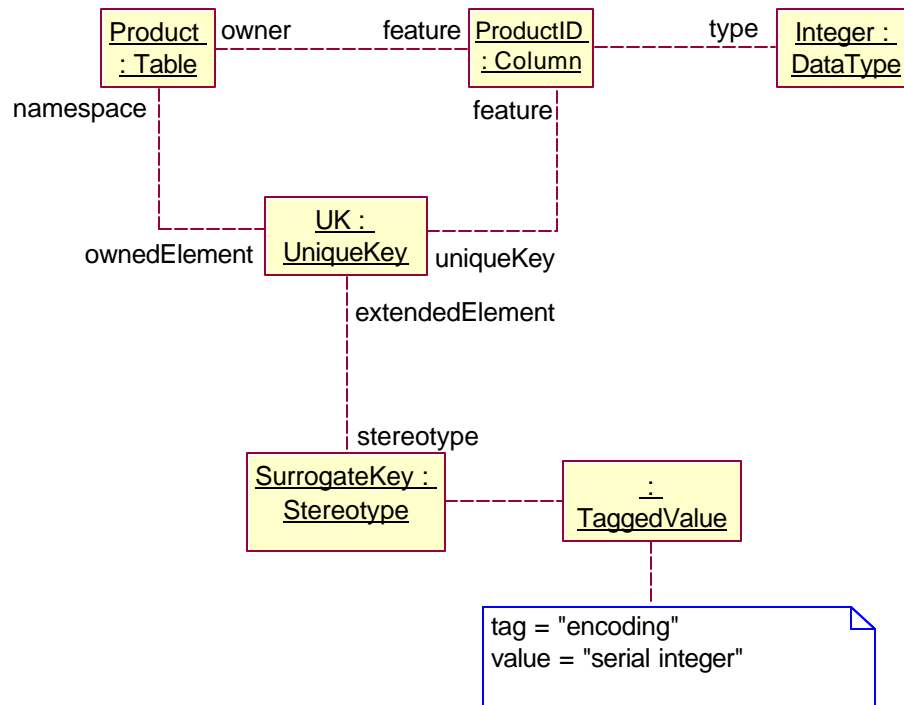

Figure 2: Instance Diagram: Surrogate Key Example